

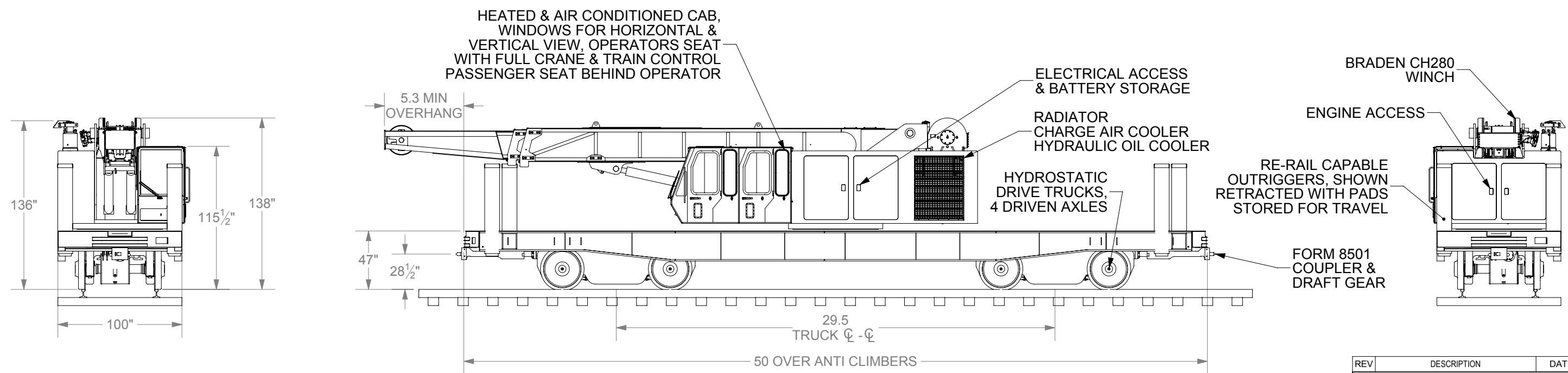
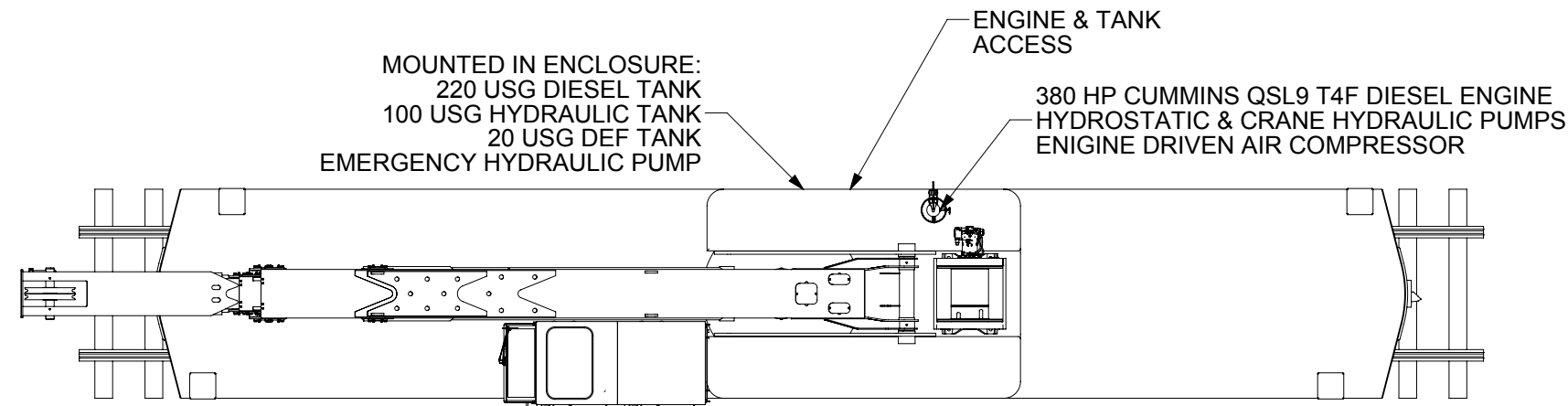
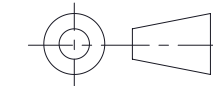

THIS PRINT AND DESIGN IS THE PROPERTY OF ARVA INDUSTRIES IS CONFIDENTIAL AND IS NOT TO BE REPRODUCED WITHOUT OUR PERMISSION AND IS TO BE RETURNED UPON REQUEST

DIMENSIONS ARE IN INCHES

FRACTIONAL	± 1/16
DECIMAL .XX	±.025
DECIMAL .XXX	±.010
ANGLES	±1/2°

REMOVE ALL BURRS AND SHARP EDGES



REV	DESCRIPTION	DATE	BY
 ARVA INDUSTRIES INC. 43 GAYLORD ROAD ST THOMAS ONT. CAN. N5P 3R9			
TITLE 35 TON RAIL BOUND CRANE			
DRAWING BY	MODEL BY	DRAWN DATE (yyMMMdd):	
CHK'D BY	LAST SAVED DATE:		
ASSY DWG	WEIGHT (lbs) 120000.00		
SIMILAR TO	SHEET 1 OF 3		
SCALE	DWG NO	REV	
1:84	EP1691	A	

DIMENSIONS ARE IN INCHES

FRACTIONAL	± 1/16
DECIMAL .XX	±.025
DECIMAL .XXX	±.010
ANGLES	±1/2°

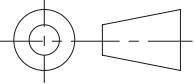

REMOVE ALL BURRS AND SHARP EDGES

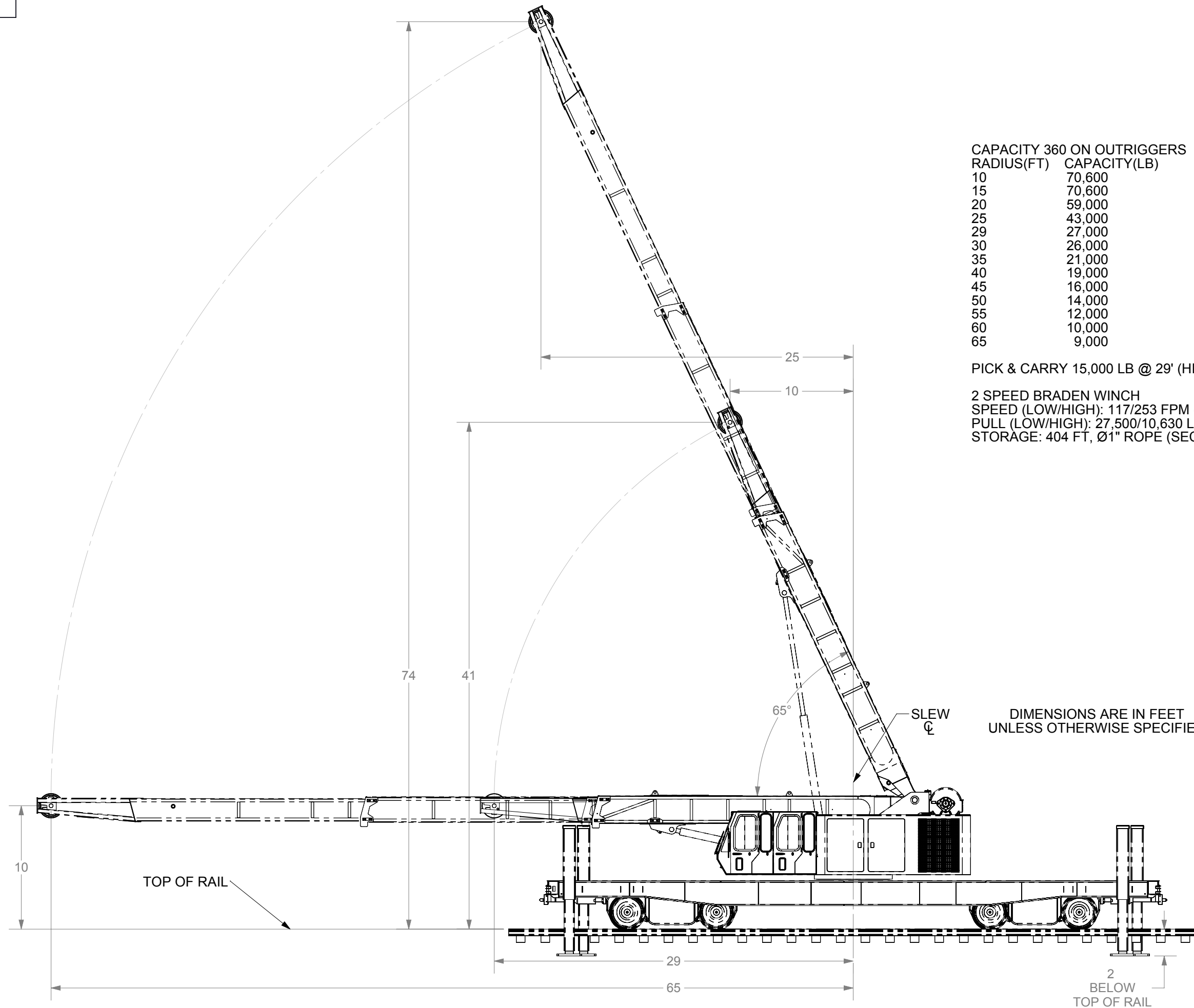

CAPACITY 360 ON OUTRIGGERS

RADIUS(FT)	CAPACITY(LB)
10	70,600
15	70,600
20	59,000
25	43,000
29	27,000
30	26,000
35	21,000
40	19,000
45	16,000
50	14,000
55	12,000
60	10,000
65	9,000

PICK & CARRY 15,000 LB @ 29' (HIGH AXLE LOAD)

2 SPEED BRADEN WINCH
SPEED (LOW/HIGH): 117/253 FPM (FIRST LAYER)
PULL (LOW/HIGH): 27,500/10,630 LB (FIRST LAYER)
STORAGE: 404 FT, Ø1" ROPE (SECOND LAYER)

DIMENSIONS ARE IN FEET
UNLESS OTHERWISE SPECIFIED

ARVA		ARVA INDUSTRIES INC. 43 GAYLORD ROAD ST THOMAS ONT. CAN. N5P 3R9
TITLE 35 TON RAIL BOUND CRANE		
DRAWING BY	MODEL BY	DRAWN DATE:
CHK'D BY	LAST SAVED DATE:	
ASSY DWG	WEIGHT (lbs) 120000.00	
SIMILAR TO	SHEET 2 OF 3	
SCALE 1:96	DWG NO EP1691	REV A

THIS PRINT AND DESIGN IS THE PROPERTY OF ARVA INDUSTRIES
 IS CONFIDENTIAL AND IS NOT TO BE REPRODUCED WITHOUT OUR
 PERMISSION AND IS TO BE RETURNED UPON REQUEST

DIMENSIONS ARE IN INCHES

FRACTIONAL	± 1/16
DECIMAL .XX	±.025
DECIMAL .XXX	±.010
ANGLES	±1/2°

REMOVE ALL BURRS AND SHARP EDGES

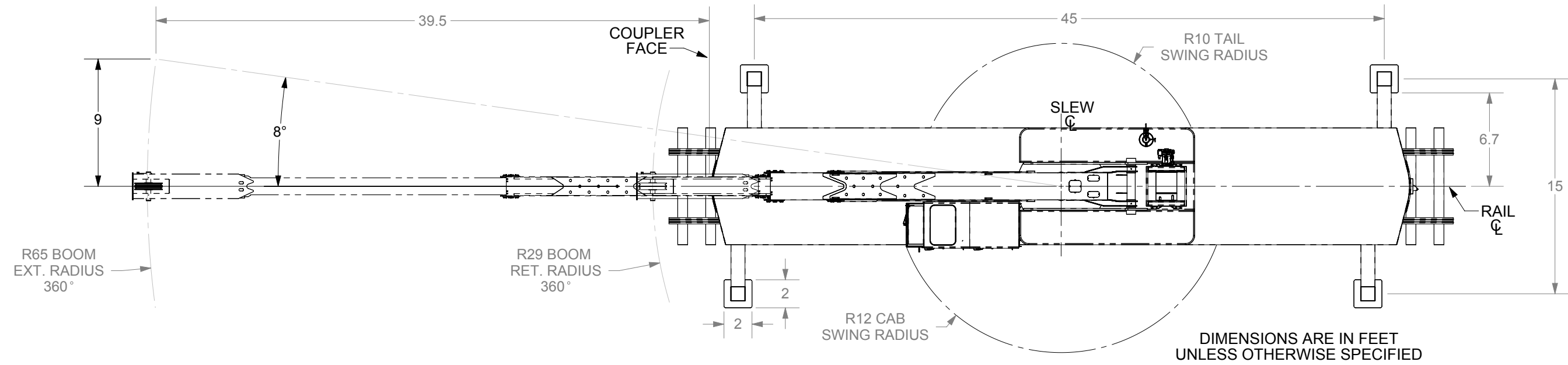
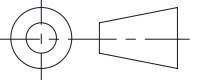

ARVA		ARVA INDUSTRIES INC. 43 GAYLORD ROAD ST THOMAS ONT. CAN. N5P 3R9	
TITLE 35 TON RAIL BOUND CRANE			
DRAWING BY	MODEL BY	DRAWN DATE:	
		LAST SAVED DATE:	
ASSY DWG			WEIGHT (lbs) 120000.00
SIMILAR TO			SHEET 3 OF 3
SCALE	DWG NO	REV	
1:96	EP1691	A	