

### MC260 SCALER:

BOOM: 3 SECTION, HYDRAULIC  
15 ft [4.6 m] RETRACTED  
23' 6" [7.2 m] EXTENDED

BOOM ANGLE: + 55 DEGREES, - 10 DEGREES

AXLES: COMER INDUSTRIES WITH INTERNAL WET  
DISC SERVICE AND PARK BRAKES

TIRES: TROJAN SOFTCORE, 35x10x15

STEERING: TWO WHEEL, FOUR WHEEL AND CRAB  
4 WHEEL DRIVE

ENGINE: CUMMINS QSB3.8 99hp, TIER 3

TRANSMISSION: ITL PS750, 4 FWD, 4 REV

CANOPY: ROPS/FOPS CERTIFIED

ANSUL 20 lb FIRE EXTINGUISHER

ANSUL A-101 FIRE SUPPRESSION SYSTEM

BACK-UP ALARM

FRONT PUSH BLADE

TRAVEL SPEED: 22 km/h (13 mph) FORWARD  
22 km/h (13 mph) REVERSE

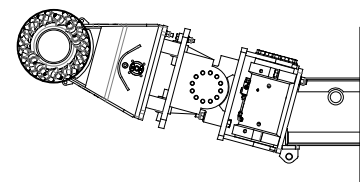
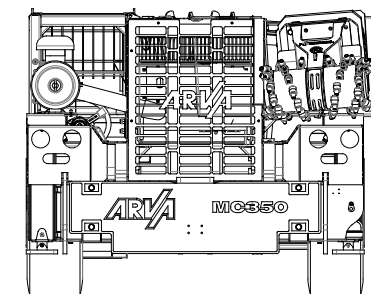
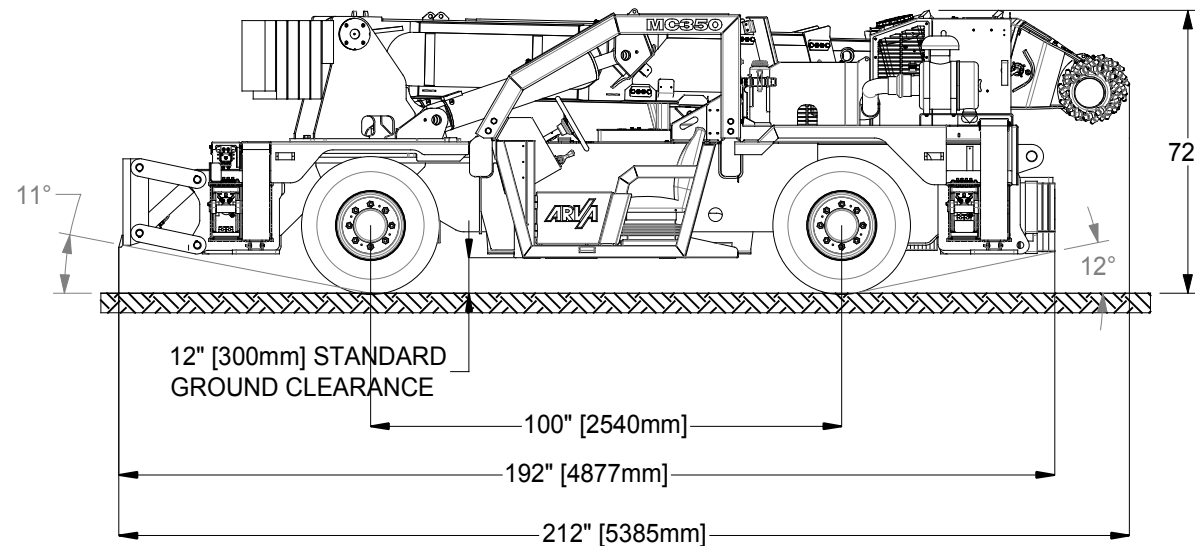
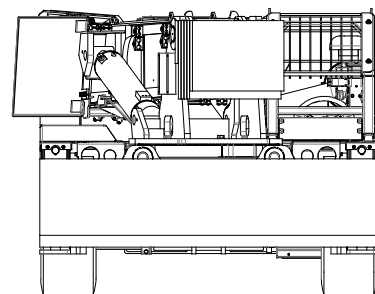

CUTTING HEAD SHOWN THROUGHOUT  
DRAWING WILL BE REPLACED BY BREAKER  
HEAD SHOWN BELOW, SAME RANGE OF MOTION

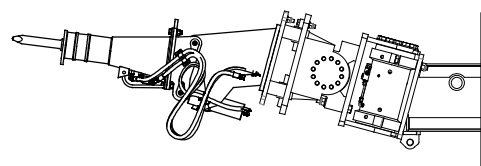

OPTIONAL RAISED CAB

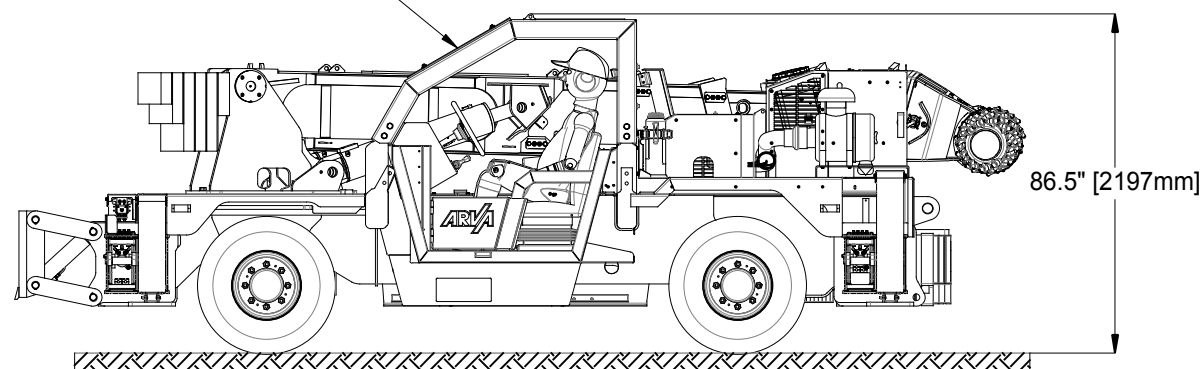

REV	DESCRIPTION	DATE	BY
ARVA INDUSTRIES INC. 43 GAYLORD ROAD ST THOMAS ONT. CAN. N5P 3R9			
TITLE MC260 SCALER			
DRAWING BY KAS	MODEL BY .	DRAWN DATE (yyMMdd): 2016-10-11	
CHK'D BY		LAST SAVED DATE: 2016-10-11	
ASSY DWG Q1610-116		WEIGHT (lbs) 21 520 LB	
SIMILAR TO		SHEET 1 OF 6	
SCALE NTS	DWG NO EP1713	REV -	

DIMENSIONS ARE IN INCHES

FRACTIONAL ± 1/16  
 DECIMAL .XX ± 0.025  
 DECIMAL .XXX ± 0.010  
 ANGLES ± 1/2°

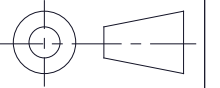

REMOVE ALL BURRS AND SHARP EDGES

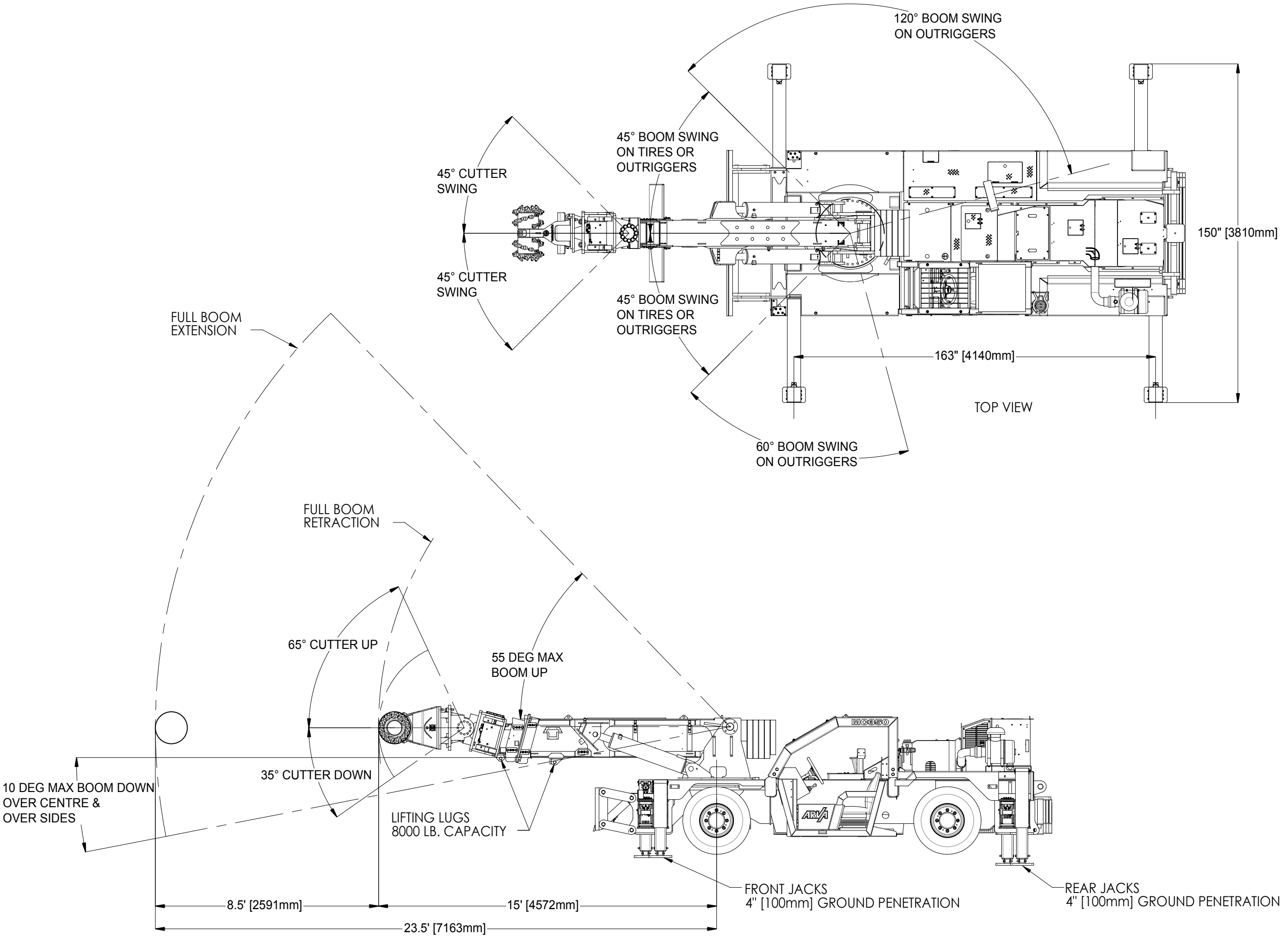

REV	DESCRIPTION	DATE	BY
 ARVA INDUSTRIES INC. 43 GAYLORD ROAD ST THOMAS ONT. CAN. N5P 3R9			
TITLE MC260 SCALER			
DRAWING BY KAS	MODEL BY .	DRAWN DATE (yy/MM/dd): 2016-10-11	
CHKD BY	LAST SAVED DATE: 15.Jul.07		
ASSY DWG Q1610-101	WEIGHT (lbs) -		
SIMILAR TO	SHEET 2 OF 6		
SCALE NTS	DWG NO EP1713	REV -	

THIS PRINT AND DESIGN IS THE PROPERTY OF ARVA INDUSTRIES  
 IS CONFIDENTIAL AND IS NOT TO BE REPRODUCED WITHOUT OUR  
 PERMISSION AND IS TO BE RETURNED UPON REQUEST

**DIMENSIONS ARE IN INCHES**

FRACTIONAL ± 1/16  
 DECIMAL .XX ± .025  
 DECIMAL .XXX ± .010  
 ANGLES ± 1/2°

REMOVE ALL BURRS AND SHARP EDGES

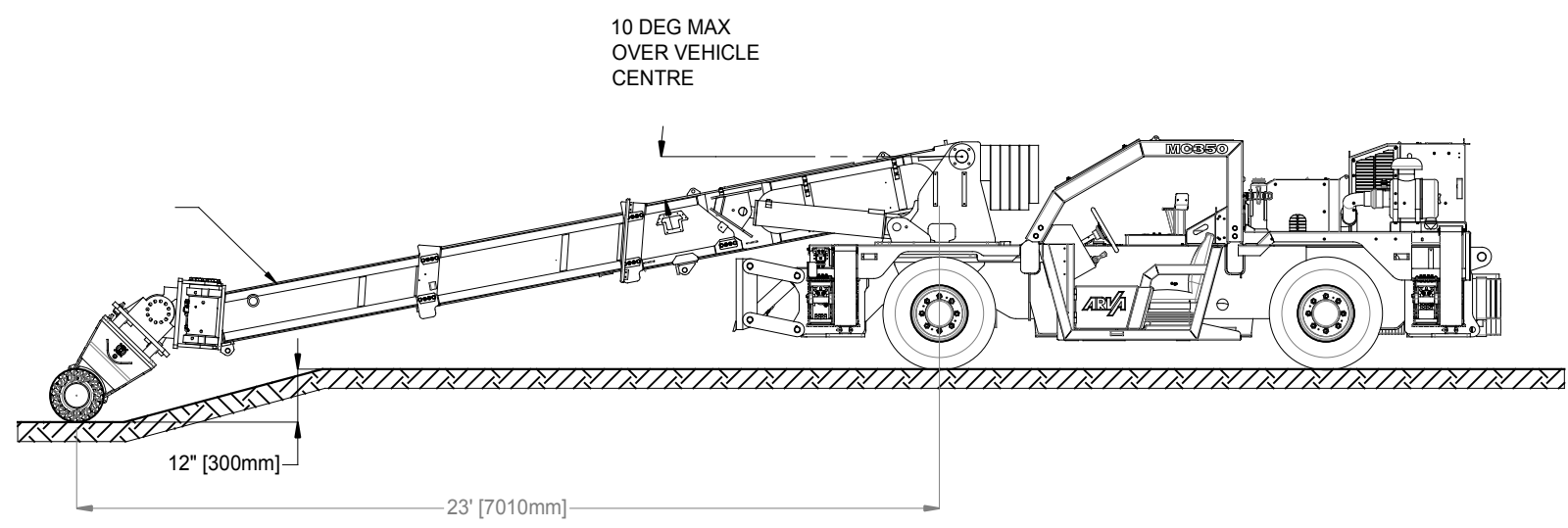
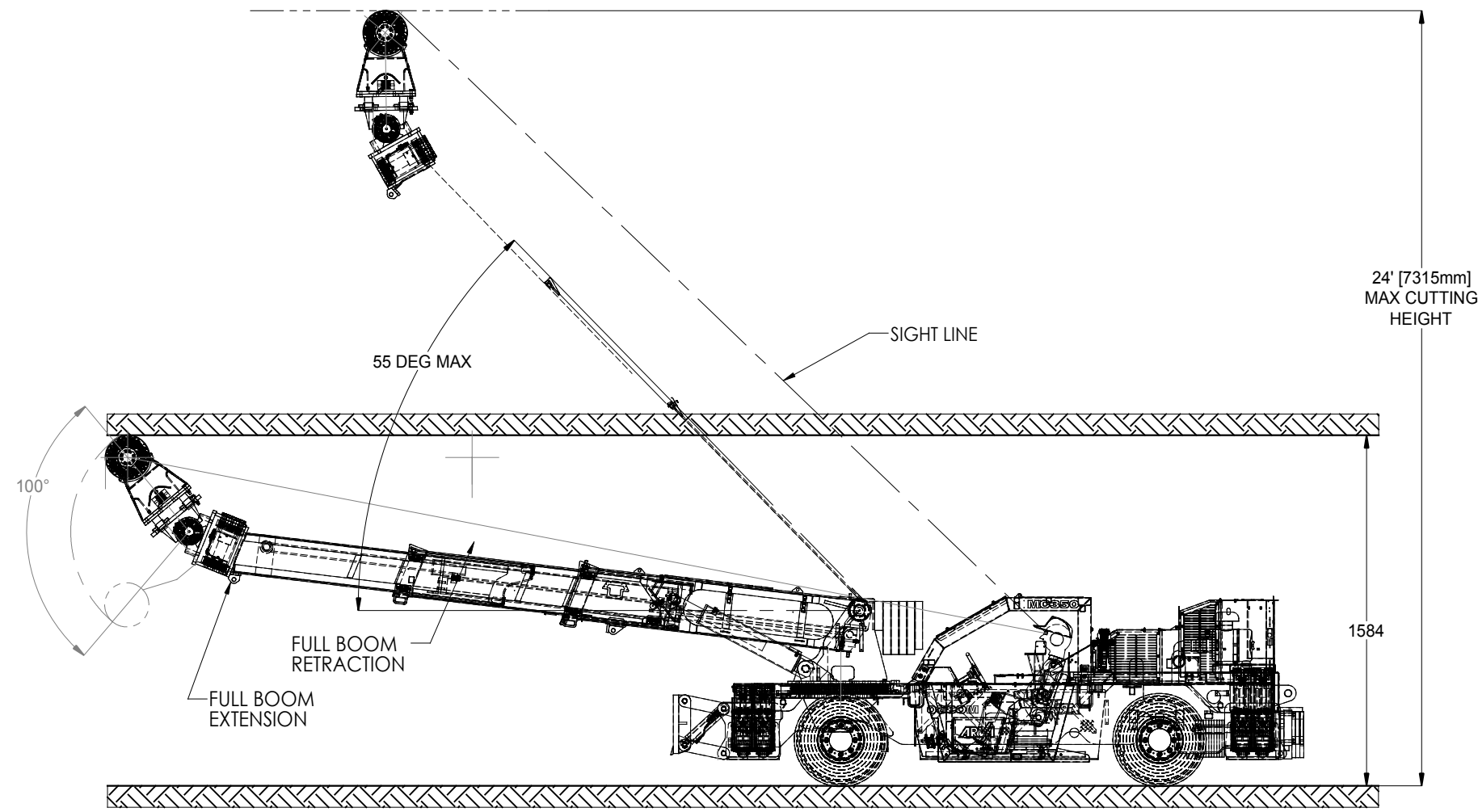

REV	DESCRIPTION	DATE	BY
 <b>ARVA INDUSTRIES INC.</b> 43 GAYLORD ROAD ST THOMAS ONT. CAN. N5P 3R9			
<b>TITLE</b> MC260 SCALER			
DRAWING BY KAS	MODEL BY .	DRAWN DATE (yy/mm/dd): 2016-10-11	
CHK'D BY		LAST SAVED DATE: 2016-10-11	
ASSY DWG Q1610-101		WEIGHT (lbs) -	
SIMILAR TO			SHEET 3 OF 6
SCALE NTS	DWG NO EP1713	REV -	

DIMENSIONS ARE IN INCHES

FRACTIONAL ± 1/16  
DECIMAL .XX ±.025  
DECIMAL .XXX ±.010  
ANGLES ±1/2°

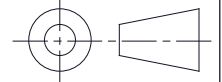

REMOVE ALL BURRS AND SHARP EDGES

OUTRIGGERS RETRACTED  
JACKS DOWN, BOOM FULLY EXTENDED  
11' [3353mm] FOOT CEILING CUT

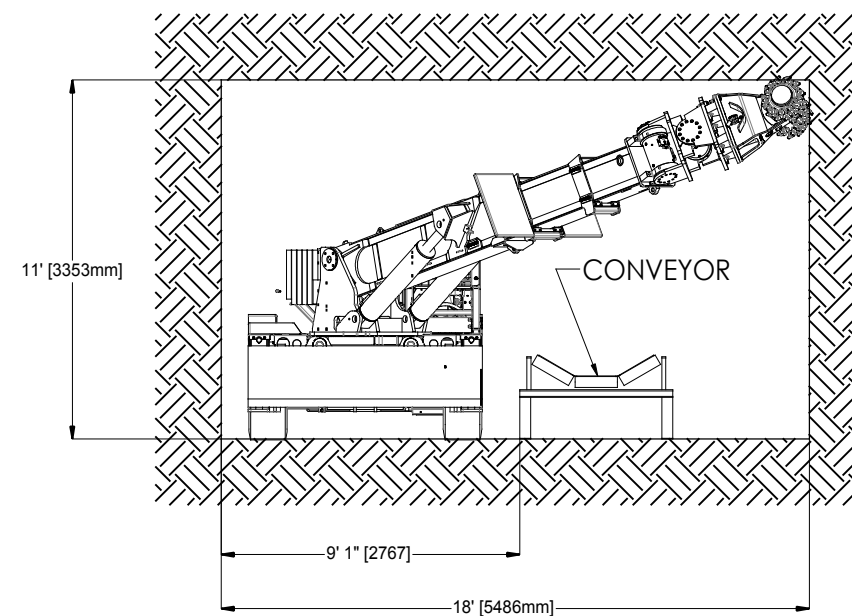
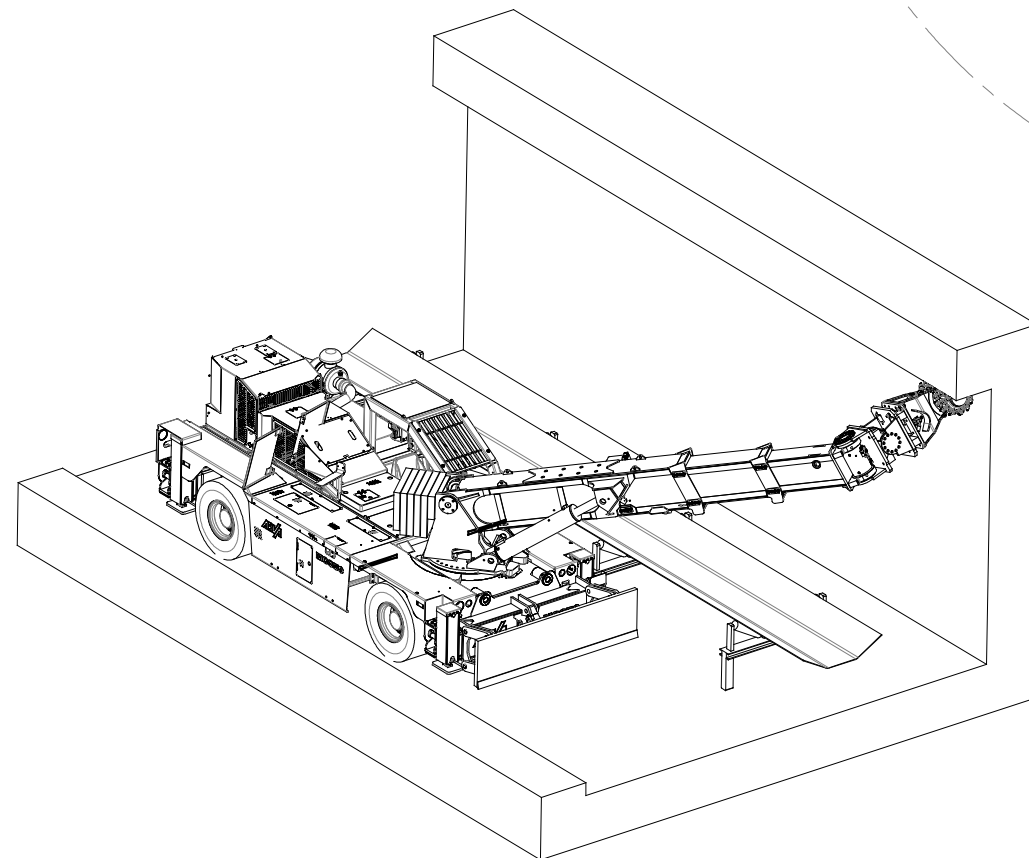
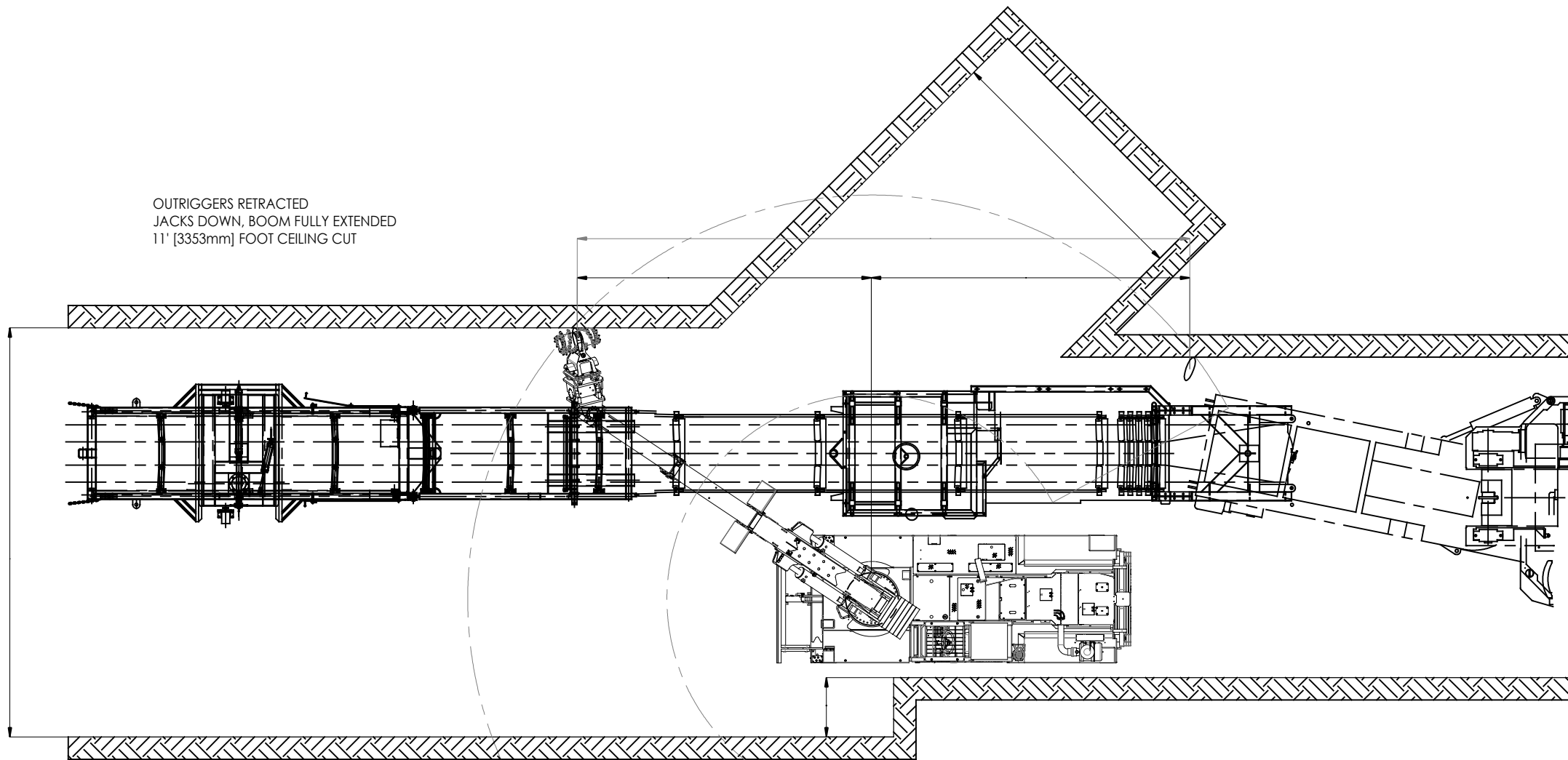

REV	DESCRIPTION	DATE	BY
 <b>ARVA INDUSTRIES INC.</b> 43 GAYLORD ROAD ST THOMAS ONT. CAN. N5P 3R9			
TITLE <b>MC260 SCALER</b>			
DRAWING BY	MODEL BY	DRAWN DATE (yyMMdd):	
KAS	.	2016-10-11	
CHKD BY		LAST SAVED DATE:	
		2016-10-11	
ASSY DWG	Q1610-101	WEIGHT (lbs)	
		-	
SIMILAR TO			SHEET 4 OF 6
SCALE	DWG NO	REV	
NTS	EP1713	-	



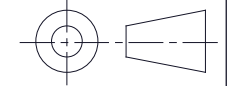

DIMENSIONS ARE IN INCHES

FRACTIONAL ± 1/16  
 DECIMAL .XX ±.025  
 DECIMAL .XXX ±.010  
 ANGLES ±1/2°

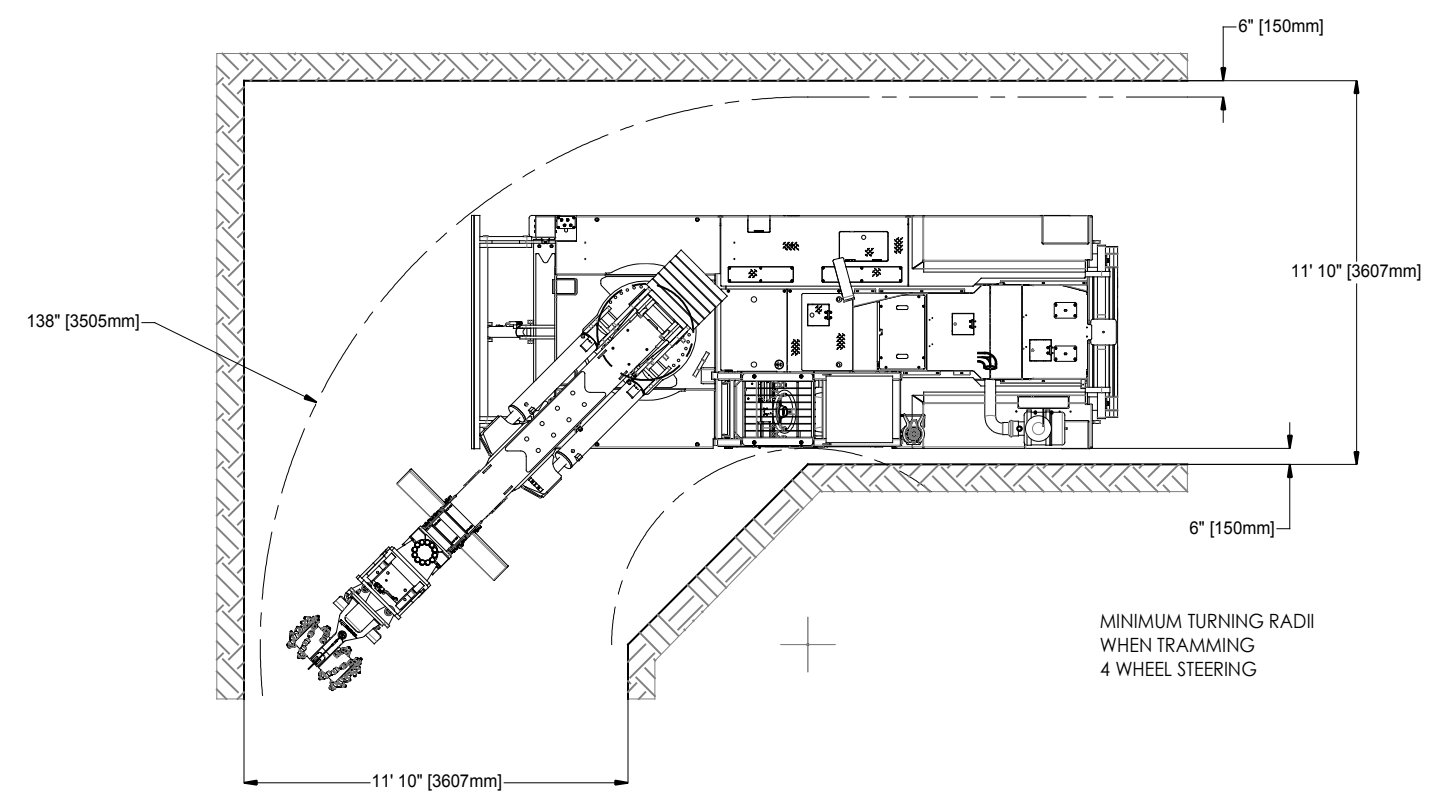
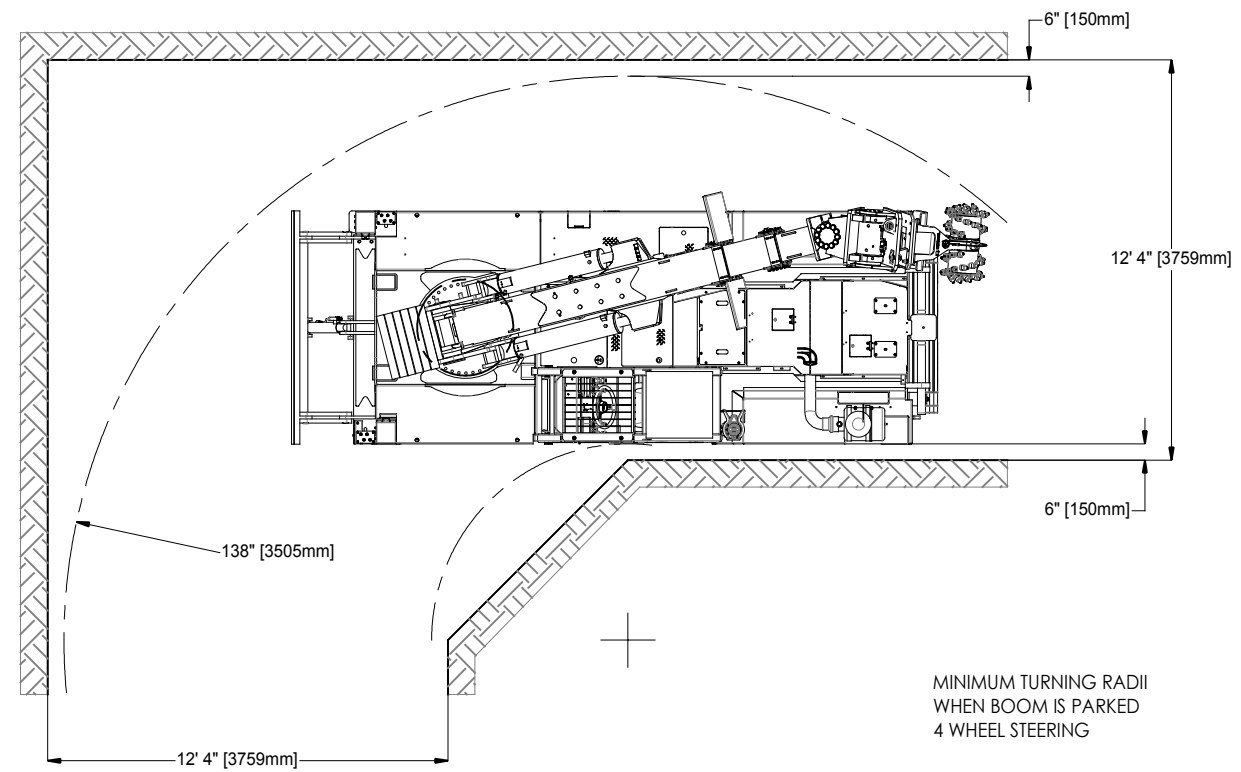

REMOVE ALL BURRS AND SHARP EDGES



REV	DESCRIPTION	DATE	BY
 ARVA INDUSTRIES INC. 43 GAYLORD ROAD ST THOMAS ONT. CAN. N5P 3R9			
TITLE MC260 SCALER			
DRAWING BY KAS	MODEL BY .	DRAWN DATE (yyMMdd): 2016-10-11	
CHKD BY	LAST SAVED DATE: 2016-10-11		
ASSY DWG Q1610-101	WEIGHT (lbs) -		
SIMILAR TO	SHEET 5 OF 6		
SCALE NTS	DWG NO EP1713	REV -	

DIMENSIONS ARE IN INCHES

FRACTIONAL ± 1/16  
 DECIMAL .XX ±.025  
 DECIMAL .XXX ±.010  
 ANGLES ±1/2°

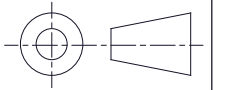

REMOVE ALL BURRS AND SHARP EDGES

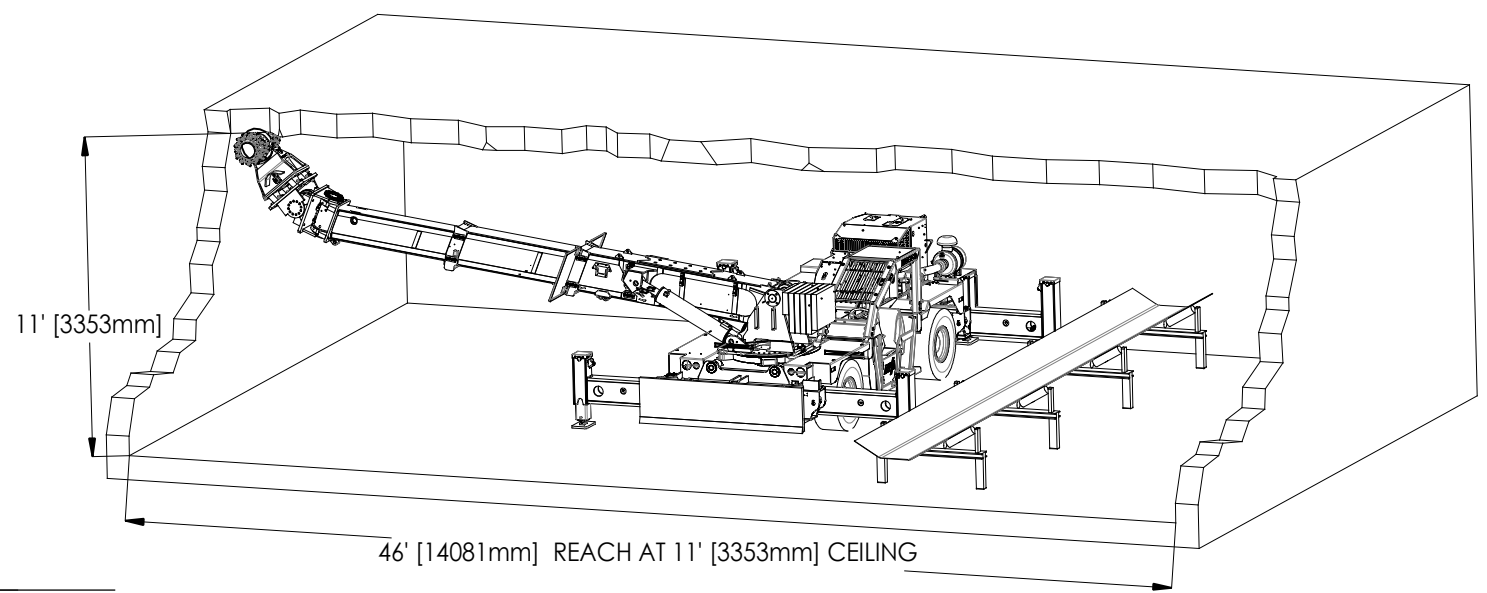
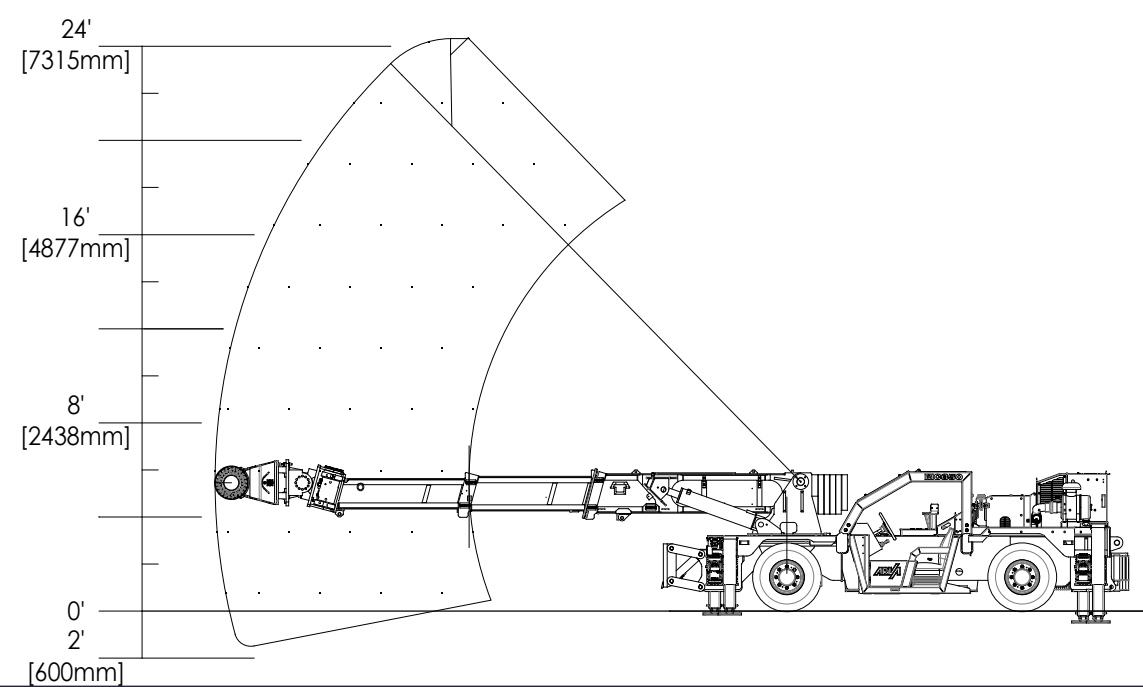
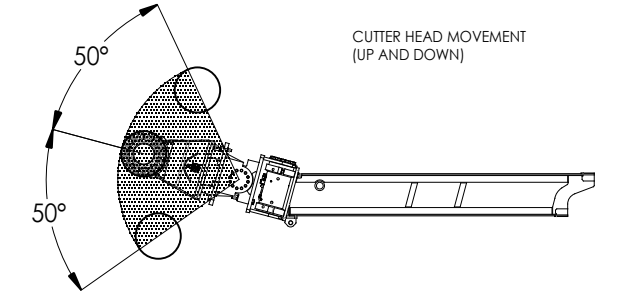
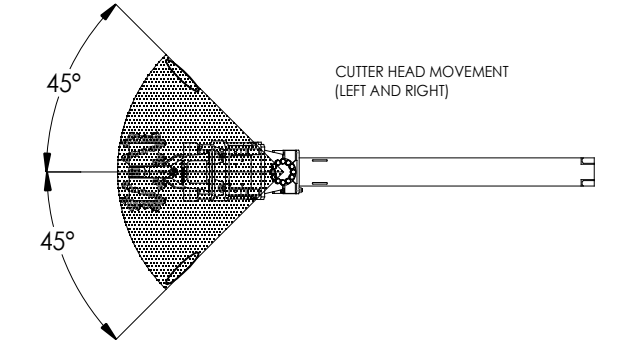
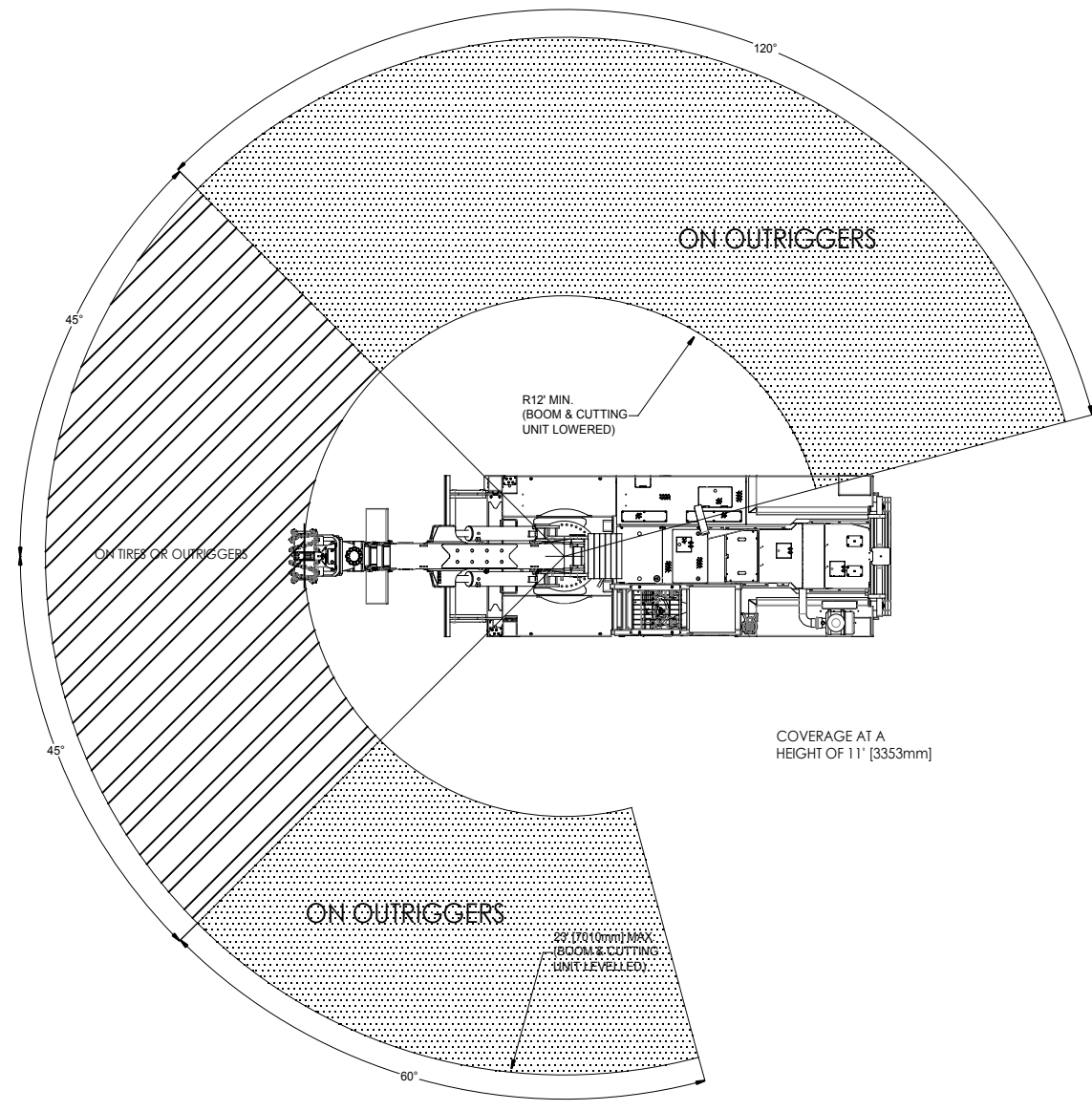
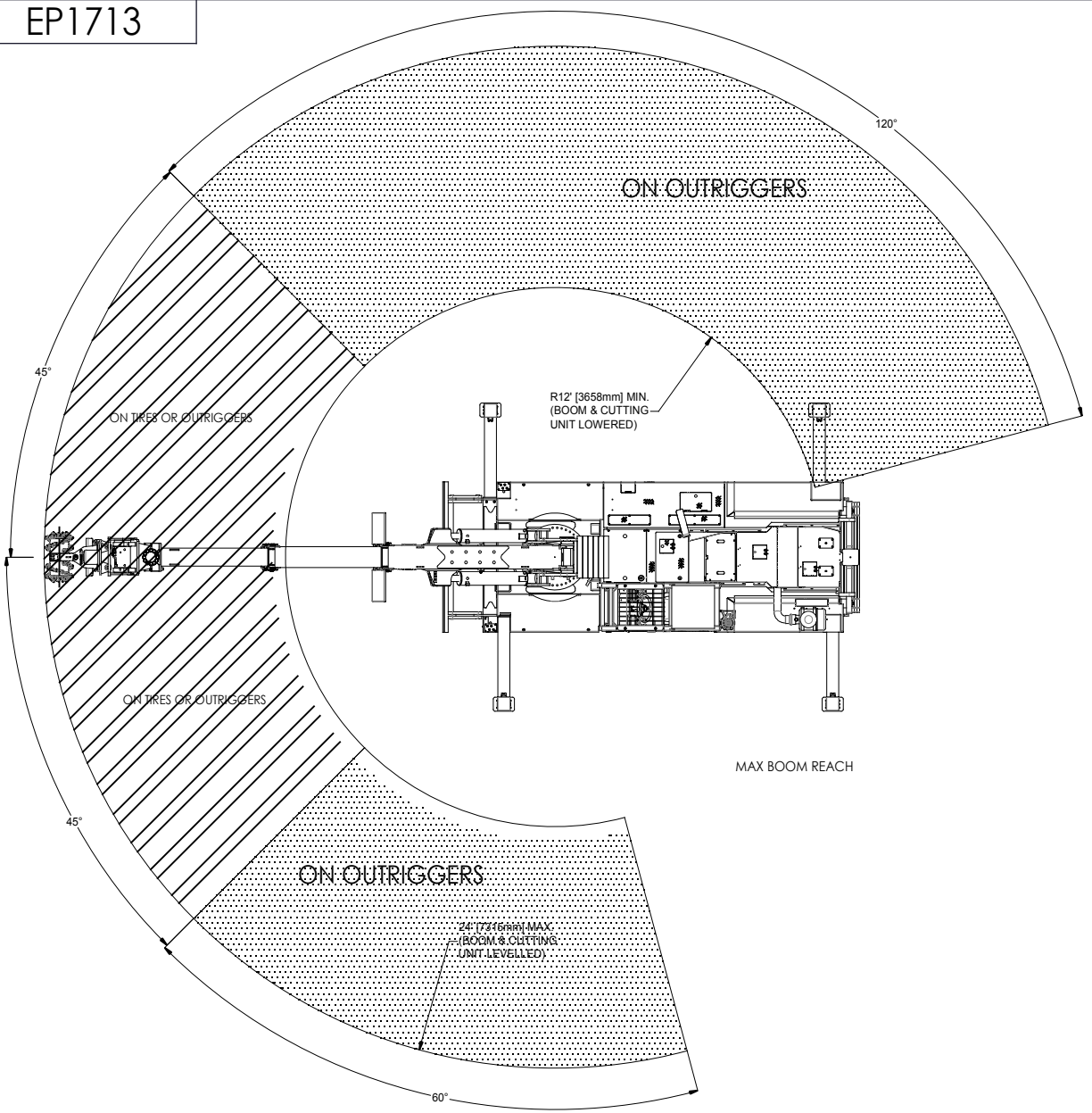

REV	DESCRIPTION	DATE	BY
ARVA INDUSTRIES INC. 43 GAYLORD ROAD ST THOMAS ONT. CAN. N5P 3R9			
TITLE MC260 SCALER			
DRAWING BY KAS	MODEL BY	DRAWN DATE (yy/mm/dd): 2016-10-11	
CHK'D BY	LAST SAVED DATE: 2016-10-11		WEIGHT (lbs)
ASSY DWG Q1610-101	SIMILAR TO		SHEET 6 OF 6
SCALE NTS	DWG NO EP1713	REV -	